



For Earth, For Life
Kubota

KX

KUBOTA COMPACT EXCAVATOR
KX030-4

Designed for efficiency, built for stability, and created for comfort,
the new KX030-4 redefines the compact excavator.



SUPERIOR PERFORMANCE

The KX030-4 gets the job done where larger excavators can't maneuver. Powerful breakout forces combined with the ability to simultaneously operate the pilot controlled hydraulic functions make the work day more productive.

Kubota original engine

The KX030-4 is powered by a proven Kubota tier 4 final diesel engine. The engine power is matched with the abilities of the hydraulic system to maximize digging and lifting performance. Operators also benefit from the minimal noise and vibration.

Auto-shift

The auto-shift automatically shifts travel speed from high to low, depending on traction and terrain, allowing smoother operation when dozing and turning.

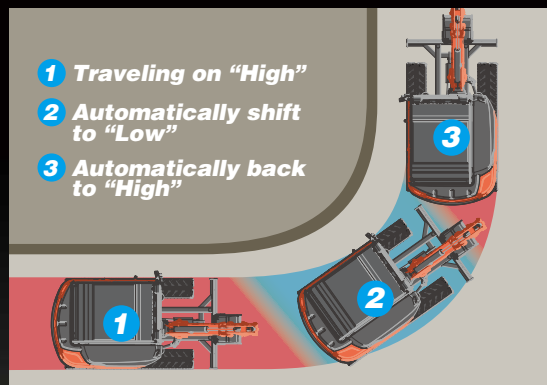

Third-line hydraulic return

When working with one-way hydraulic attachments, such as a breaker or brush cutter, the standard third-line hydraulic return system allows oil flow directly to the tank without having to return oil back through the main control valve. This simple flow return system provides greater flow efficiency, reduced back pressure and less heat.



Thumb bracket and relief valves

The factory installed mount brackets and hydraulics significantly reduce the time needed to mount accessories.

AUX diverter valve

The diverter valve allows the hydraulic thumb attachment to remain connected while diverting oil flow to other auxiliary attachments when needed, reducing transition time between attachments and improving overall productivity.

Powerful breakout force

The KX030-4 delivers an impressive bucket breakout force of 6924 lbs. The powerful and well-balanced arm and bucket design allows the operator to dig faster, deeper (9'7" / 2980 mm) and more efficient even in the toughest conditions. The working range for reach and dig depth are excellent that operators will appreciate in terms of daily productivity.

Simultaneous operation

Many jobs require the simultaneous operation of the boom, arm, bucket, and swivel for efficient operations. There are two variable displacement pumps that distribute a correct amount of oil flow to each function according to the joystick lever stroke. The ability of simultaneous operation enables continuous high production while performing multiple functions.



Proportional flow control of auxiliary circuit

The thumb-operated switch on the right joystick allows easy proportional flow control of the AUX circuit.



Right control lever

Dozer blade float

You don't need to adjust the dozer height to make a clean ground surface. After backfilling, just travel backward along the covered ditch with the dozer in the float position. Ground finishing work is now fast and easy!



SPACIOUS CAB DELUXE INTERI

The large cab* offers a wider entrance, greater leg room, more floor space and a luxurious interior to make the work day more comfortable. Operability is greatly enhanced with more easy-to-use features than ever before. *Heater only

Large operator's station

With a large and comfortable operator's station, the KX030-4 offers an extra level of comfort and convenience that operators are sure to appreciate during long jobs.

New front meter panel

The new user-friendly front meter panel puts convenience at your fingertips. Positioned to the front right corner of the operator for better visibility and accessibility, it features easy one-touch button operation to view the time, hour meter, and tachometer. Warning lamps with codes on the display will alert you of machine conditions such as overheating, hydraulic system monitoring, or a low battery.

1. Fuel Level Gauge
2. Water Temperature Gauge
3. Warning Lamps
(Engine oil pressure, Battery charge, Coolant temperature)
4. LCD Display (Time, Hour, rpm)

Time



Hour Meter



Tachometer

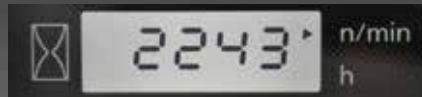

Easy-open front slide window

Unlike many excavator windows, the front glass window of the KX030-4 opens with ease. Just flip the latches on the window sides and slide it up. A gas-assist mechanism makes this action almost effortless.



AND OR



A. Flat foot space

The flat foot space enables easy entry and exit and enhances comfort by providing ample leg room to reduce fatigue even during long hours of operation.

B. 2-speed travel switch

By conveniently placing the 2-speed travel switch on the dozer lever, dozing operations can be done faster and easier without having to remove your hand from the dozer control lever during operation.



C. Cup holder

With the convenience of a bigger cup holder, you can quench your thirst and work longer without leaving your seat.

D. Wrist rest

A thoughtfully designed wrist rest enhances operation and reduces operator fatigue.

E. Suspension seat

Designed for better fit and comfort for long hours of work, Kubota's standard highback suspension seat minimizes strain and operator fatigue by accommodating your individual posture and weight. A seat belt is fitted as standard with a 3" available as an option.

Easy Cab entry and exit

The wide cab entrance allows quick access in and out for those jobs where you spend your day continually on the move.

TPSS

The Two-Pattern Selection System positioned under the seat allows the operator to shift control styles conveniently while seated. A simple turn of a switch is all it takes to select between the ISO pattern and the SAE backhoe pattern. This standard feature allows operators to choose their preferred choice of operation for comfort and efficiency.



MAINTENANCE & SAFETY

With the KX030-4, operators can work with confidence knowing they are protected by the ROPS/OPG on both the open station or optional enclosed cab. Furthermore, the engine compartment is ergonomically organized with easy access to the radiator and engine oil cooler to make routine maintenance and inspections a breeze.

ROPS/OPG (top guard, level I) canopy and cabin

The ROPS/OPG (Top Guard, Level I) canopy / cabin provides protection in the event of accidental rollovers and falling objects.

- A. Battery**
- B. Oil cooler**
- C. Radiator**
- D. Air cleaner**
- E. Engine coolant reservoir tank**
- F. Fuel filter**
- G. Water separator**



Protected cylinder hoses

The cylinder hoses for arm and bucket are located inside the boom to protect the hoses from any type of damage.

Travel lock system

The travel lock system locks the tracks to prevent inadvertent movement of the machine. This keeps the excavator secure during transport or while parked on slopes.

Swivel negative brake

The swivel negative brake automatically locks the swivel function in its current position. This prevents unexpected machine movement. It's particularly useful during work on slopes or when transporting the excavator between worksites.

Tie down points

For secure transportation, tie down points are installed on the track frame, swivel frame, and the dozer.

KX030-4 EQUIPMENT

STANDARD EQUIPMENT

Machine safety system

- Travel lock system
- Fully locked hydraulic system
- Swivel negative brake
- Tie down brackets

Working equipment

- 2 working lights on cab and 1 light on the boom
- Auxiliary hydraulic circuit 1 with proportional control on right control lever
- Thumb bracket and relief valve
- Dozer Blade

Operator's space

- ROPS/OPG(Top Guard Level I) canopy
- Weight adjustable suspension seat
- Retractable seat belt
- Hydraulic pilot control levers with wrist rests
- Two pattern selection system
- Front meter panel with diagnosis function

- 12V power outlet
- Cup holder
- Horn

Engine/Fuel system

- Double element air filter
- Water separator with drain port

Undercarriage

- 11.8" (300mm) rubber track
- Double flange track roller
- 2-speed travel switch on dozer lever
- 2 speed travel with auto-shift

Hydraulic system

- Variable displacement pump
- Hydraulic pressure checking ports
- Pressure accumulator
- Straight travel circuit
- Third line hydraulic return
- Auxiliary circuit with proportional control

- AUX diverter valve
- AUX oil flow adjustable from digital panel

Others

- Tool box
- Grease gun holder

OPTIONAL EQUIPMENT

- Cab with heater only
- Travel alarm
- Canopy lights
- Cab mirror
- Travel foot pedal
- 3" Seat Belt
- Cab Radio

WORKING RANGE

Model			KX030-4
A	Max. digging height	ft. in. (mm)	15'1" (4610)
B	Max. dumping height	ft. in. (mm)	10'4" (3180)
C	Max. digging depth	ft. in. (mm)	9'7" (2980)
D	Max. vertical digging depth	ft. in. (mm)	6'7" (2070)
E	Max. digging radius at ground	ft. in. (mm)	15'9" (4860)
F	Max. digging radius	ft. in. (mm)	16'3" (4970)
G	Min. turning radius	W/O swing	ft. in. (mm) 6'5" (1980)
		W swing	ft. in. (mm) 5'1" (1570)
H	Min. tail turning radius	ft. in. (mm)	3'9" (1200)

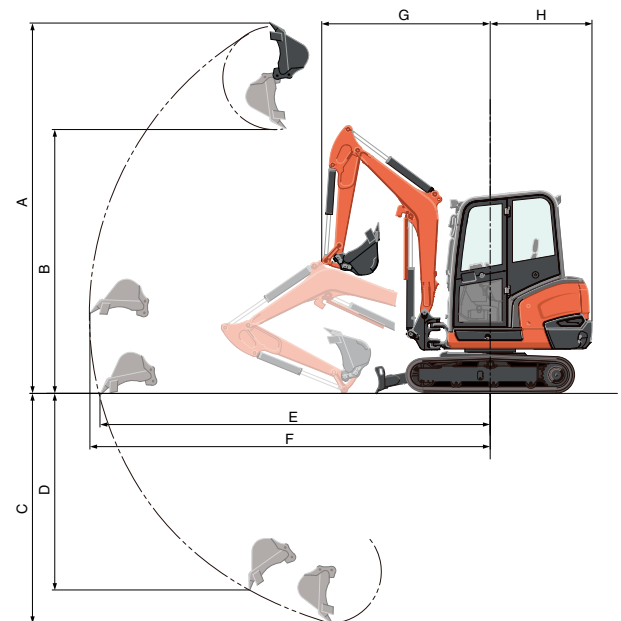

LIFTING CAPACITY

LIFT POINT HEIGHT (ft)	LIFTING CAPACITY OVER-FRONT BLADE DOWN			LIFTING CAPACITY OVER-SIDE			
	LIFT POINT RADIUS (ft)			LIFT POINT RADIUS (ft)			
	8	10	12	8	10	12	
GL	6	1.55	1.30	1.17	1.55	1.13	0.86
	4	2.00	1.50	1.26	1.51	1.09	0.83
	2	2.34	1.67	1.34	1.43	1.04	0.81
	0	2.43	1.75	1.36	1.39	1.01	0.79

unit: 1000 lbs

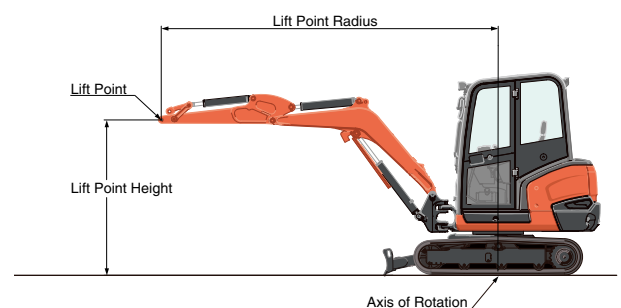

SPECIFICATIONS

Model		KX030-4	
Type of ROPS/FOPS		Canopy / Cab	
Type of tracks		Rubber	
Engine	Model	V1505-E4-BH-3USA	
	Output (SAE J1995 gross)	HP (kW) / rpm	24.7 (18.4) / 2250
	Output (SAE J1349 net)	HP (kW) / rpm	23.7 (17.7) / 2250
Dimensions	Overall length	ft. in. (mm)	15'1.1" (4600)
	Overall height	ft. in. (mm)	7'11" (2420)
	Overall width	ft. in. (mm)	4'11" (1500)
	Min. ground clearance	in. (mm)	11.6" (295)
Hydraulic system	Pump capacity	gpm (ℓ/min.)	8.3 (31.5) × 2 / 4.7 (18) × 1
	Auxiliary hydraulic flow	gpm (ℓ/min.)	13.1 (49.5)
	Max. breakout force	Bucket / Arm lbs. (kgf)	6924 (3140.7) / 3484 (1580.6)
Drive system	Travel speed	Low / High mph (km/h)	1.7 (2.7) / 2.7 (4.3)
	Max. traction force	Low speed lbs. (kgf)	7330 (3325)
	Tumbler distance	ft. in. (mm)	5'1.4" (1560)
	Crawler length	ft. in. (mm)	6'5.9" (1980)
	Shoe width	Rubber in. (mm)	11.8" (300)
	Ground contact pressure	Canopy / Cab psi (kgf/cm ²)	3.9 (0.27) / 4.0 (0.28)
Swing system	Unit swing speed	rpm	9.2
	Boom swing angle	Left / Right degree	76 / 57
Blade	Dimension	Width ft. in. (mm)	4'11" (1500)
		Height in. (mm)	11.8" (300)
	Max. lift above ground	in. (mm)	13.8" (352)
	Max. drop below ground	in. (mm)	13.5" (345)
Hydraulic oil (reservoir / system)		gal (ℓ)	9.0 (33.9) / 13.7 (52.0)
Fuel reservoir		gal (ℓ)	12.7 (48.0)
Operating weight (Includes operator weight 175lbs.)		Canopy / Cab lbs. (kgf)	6272 (2845) / 6426 (2915)

DIMENSIONS

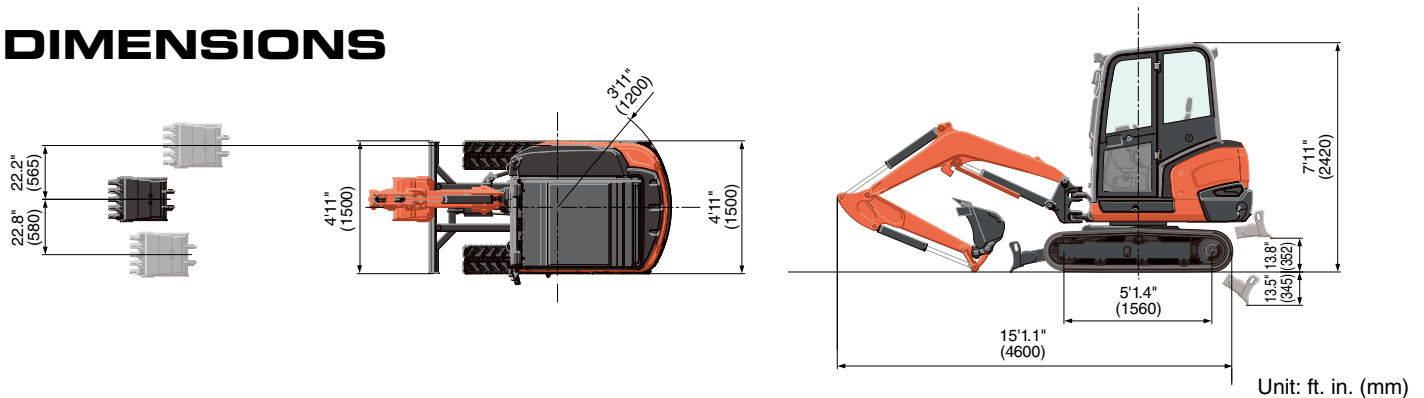

Kubota Tractor Corporation reserves the right to change the stated specifications without notice. This brochure is for descriptive purposes only and reasonable efforts were used to set forth the contained information; some items shown may be optional and some products shown may not be available at all dealerships. Kubota disclaims all representations and warranties, express or implied, or any liability from the use of this brochure. For complete warranty, safety and product information, consult your local Kubota dealer and the operator's manual. Power (HP/KW) and other specifications are based on various standards or recommended practices. For your safety, Kubota strongly recommends the use of a Follower Protective Structure (ROPS) and seat belt in almost all applications. This brochure is intended for the United States and US territories only. For information regarding Kubota products or services outside these areas, see Kubota Corporation's global web site. Kubota does not provide parts, warranty or service for any Product which is re-sold or retailed in any country other than the country for which the Product(s) were designed or manufactured.



KUBOTA TRACTOR CORPORATION

1000 Kubota Drive, Grapevine, TX 76051 Tel 888-4 KUBOTA

Visit our web site at: www.kubotausa.com

©2022 Kubota Corporation



**Kubota
Genuine Parts**
for maximum
performance,
durability and
safety

