



For Earth, For Life
Kubota

KX

KUBOTA COMPACT EXCAVATOR KX040-5

The superior compact excavator that combines exceptional strength and versatility with performance and user-friendly operation.



OPERATOR COMFO

A wide and roomy cab brings a new level of operating comfort to the job.

Spacious & Comfortable Cab

With new interior designs, the cabs offer improved comfort for operators of any size. The designs feature a slimmer, more ergonomically positioned right meter panel and greater head/foot space. The result is more room and greater comfort for the operator, and that means improved productivity on the job.



A. Back-lighted Key Pad

Redesigned for greater comfort and improved operability, the key pad features a compact profile and places all of the main switches on the right side for easier access.

B. Air-suspension seat (option)

An optional air suspension seat provides new comfort and height controlled by the air compressor.

C. Enhanced Legroom

The new cab design and interior layout not only optimizes operability, but also provides much more foot space for greater operator comfort.

RT / EASE OF USE



Expanded Glass Area

A slimmer frame design means more glass in the front window, skylight, and left and right windows. Operators can monitor the bucket through the skylight during truck loading or demolition operations—it also enhances the feeling of spaciousness in the cab.



Low Noise 72dB*

A quieter cabin provides a more stress-free working environment. The low noise level protects the operator from engine noise and other loud sounds.

* Test conditions : Kubota in-house test result. During simple dirt excavation with door closed and heater at level 2. Actual results may vary.

Air Conditioner

The air conditioner duct now directs air to the back of the operator's neck to enhance the effect and efficiency of the air conditioning.



WORKING PERFORMANCE

Advanced hydraulic systems and blade control ensure superior performance and operability in real-world working conditions.

ESS (Engine Speed Sensing)

By introducing ESS, the engine horsepower can now be utilized to its fullest extent. This has allowed the flow rate to be increased through electronic control, whereas in the past the flow rate was set to be limited so as not to stall when a load was applied. This has made both excavation work and the use of high-flow rotating attachments more efficient.

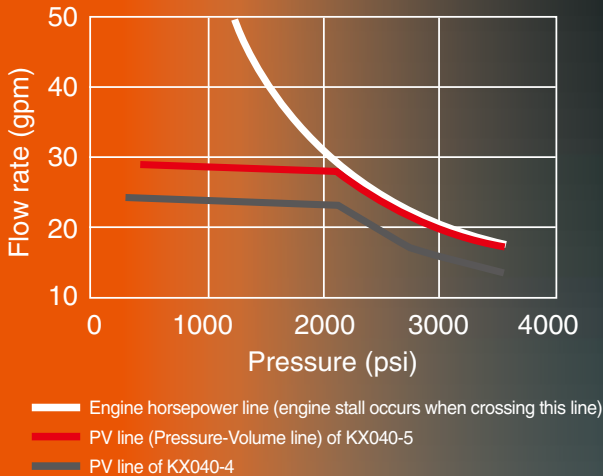

Proportional flow control of auxiliary circuit (AUX1/2) and maximum oil flow setting

The KX040-5 is available with a standard AUX1 and optional AUX2 auxiliary circuits. The convenient thumb-operated switch on the lever allows easy proportional flow control of the auxiliary circuit, while a forefinger-operated on/off switch enables simple operation of special applications that require a constant oil flow. The maximum oil flow setting is



conveniently adjustable from the digital panel. Up to five flow rates corresponding to specific attachments can be programmed in the memory on the digital panel for easy retrieval for the next job.

Engine Auto Stop

The Engine Auto Stop system comes fitted as standard. The engine turns off automatically when it's been left idling too long. You can set the idling time to suit you.



PERFORMANCE

Auto-shift

The auto-shift system enables automatic travel shift from high to low depending on traction effort and terrain. This gives smoother operations when dozing and turning.



Float position

The float function is a standard feature on the KX040-5. Ground finishing work can be completed quickly and simply without the need to adjust the dozer height. After backfilling, simply travel backwards along the covered ditch with the dozer in the float position.



Working Range

Kubota's updated 4 ton compact excavators deliver impressive performance and efficiency for their size, with exceptional bucket digging force, outstanding arm reach, and a well-matched arm and bucket. Even tough digging jobs will get done faster and more efficiently.

Angle Blade Models



Save time and work more efficiently. With a simple movement of the blade lever, the hydraulic angle blade can be angled to the right or left to push soil to the side as the machine moves forward, eliminating the need for repetitive repositioning at right angles when backfilling trenches.

Hydraulic 6-in-1 Blade Models



The 6-in-1 blade is a true productivity enhancer. Same with the previous model, it can be angled right and left, and tilted as well. This blade enables six different positions: neutral, float-up, left-end-up, right-end-up, left-end-forward and right-end-forward. This feature makes leveling and backfilling work incredibly easy, even on inclines and uneven terrain, making you more productive and more efficient.

Proportional tilt blade control

Kubota's hydraulic 6-in-1 Blade now offers the proportional control function, so operation is even more rewarding. Blade up, down, and float functions are the same as the previous model. Operate the rocker switch on top of the blade control to tilt the blade 10° up or down, and simply twist the control handle to angle the blade 25° left or right. Command all six functions simultaneously for more convenient control of landscaping, shaping, and backfilling jobs.



TECHNOLOGY

Advanced technology helps keep the operator and bystanders informed about the machine.

Keyless Start

Keyless start is standard. The engine can be started by entering a 4 digit passcode using the excavator key pad and up to 10 user passwords can be set. With this new function, customers no longer have to worry about lost keys.

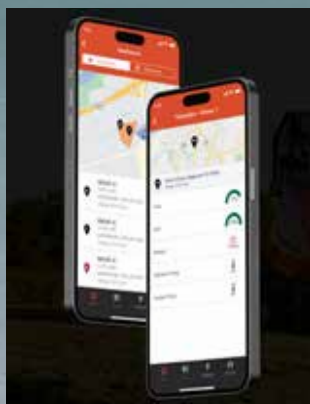
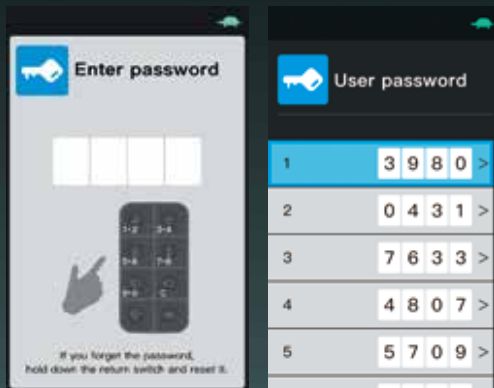

Telematics Standard

The Kubota telematics solution connects your Kubota equipment to your tools. Get critical information like accumulated hours, fuel level, location, temperatures and more. KubotaNOW gives you the right information when and where you need it.

LED Work Lights with Turn-off Delay

The LED work lights can be programmed to turn off 30 seconds to 2 minutes after the engine has stopped. This allows the operator to exit the machine and walk away under full illumination.

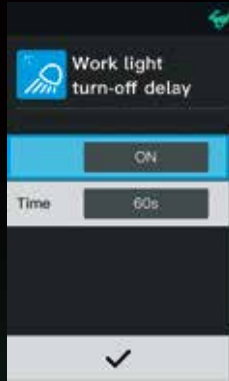

Rear-view Camera (option)

Factory designed rear-view camera provides a fish-eye view to the rear of the KX040-5 by displaying the view on the 7" LCD screen in the cab.



Automatic Activation of 3rd Line Hydraulic Return

No more climbing down from the cab and reaching under the bonnet to manually open and close the 3rd line hydraulic return. The KX040-5 features an electronically controlled 3rd line hydraulic return that is automatically activated when the operator selects one way flow mode on the digital panel in the cab.

SERVICE

A fully opening bonnet and optimum arrangement of internal parts realize quick and efficient service and shorter downtime.

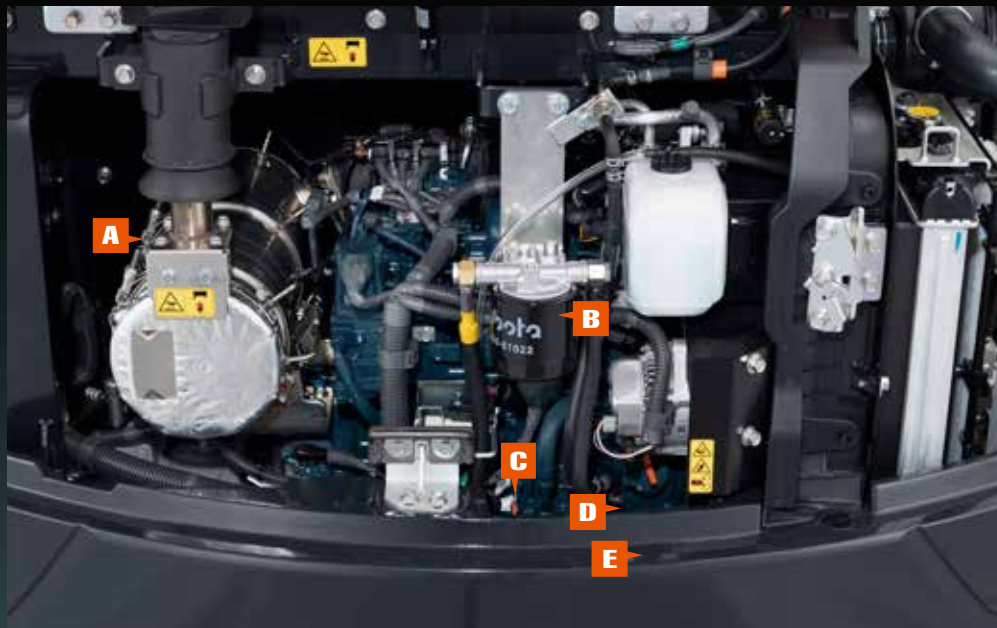

- A DPF MUFFLER**
- B FUEL FILTER**
- C ENGINE OIL GAUGE**
- D ALTERNATOR**
- E STARTER MOTOR**

One-sided Engine Maintenance

Kubota has made routine maintenance extremely simple by consolidating primary engine components onto one side for easier access. The engine and other vital components can be inspected quickly and easily.

Side-hood Features

The radiator, oil cooler and A/C condenser are conveniently positioned inside the side-hood bonnet. The new layout of A/C condenser provides an easier and more efficient way to clean and maintain the cooling system. This keeps your machine performing its best and prevents the excavator from overheating

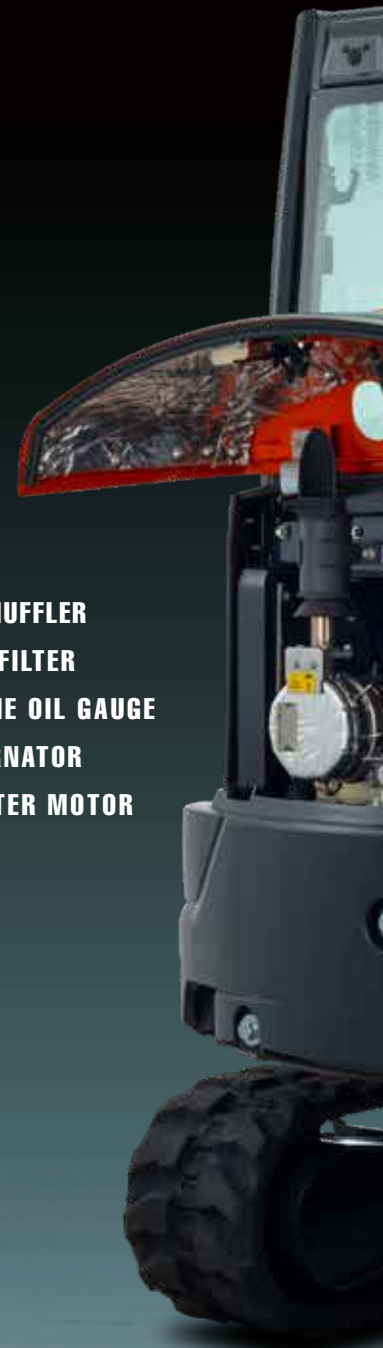



Two-piece Hose Design

When an on-site replacement of a dozer cylinder supply hose is necessary, its two-piece design simplifies the job.



Protected Cylinder Hoses

The bucket cylinder hoses are located inside the arm. The boom cylinder hoses are routed under the bottom of the boom.

Intuitive operation and large LCD screen help to enhance performance.

DIGITAL PANEL

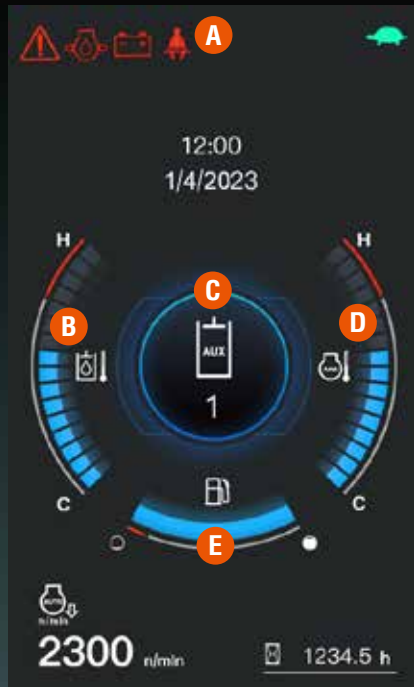

Standard Monitor Display

New Full-Color LCD Screen With Jog Dial

A full-color, high-resolution 7" LCD screen provides, with a single glance, all the information the operator needs to operate the compact excavator. An intuitive interface ensures quick understanding and easy access to the compact excavator's various functions, including AUX flow adjustment. Important maintenance items are also displayed, as are detailed alerts for improper machine functions and abnormalities. The new jog dial is both intuitive and easy to use. Even first-time operators will be able to quickly access all important information. A keyless start system is standard for the operator's convenience.

Menu icons



- A. Alert Indicator
- B. Hydraulic Temperature
- C. AUX Mode
- D. Water Temperature
- E. Fuel Level



Periodic Check



AUX Setting

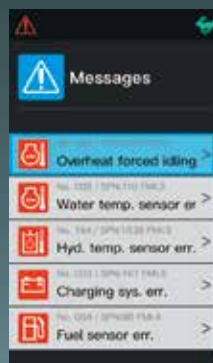

Message Mode

CAN Radio with Bluetooth (CAB only)

Standard on CAB units, our integrated bluetooth radio allows for seamless bluetooth streaming and hands free calling.



- A. Menu Key
- B. Return Key
- C. Jog Dial
- D. Working Light
- E. Beacon Light (Opt.)
- F. Auto Idle
- G. Wiper
- H. Rear-view Camera (Opt.)
- I. Washer Fluid
- J. Travel Alarm Off (Opt.)



KX040-5 OPTIONS

STANDARD EQUIPMENT

Safety system

- Engine start safety system
- Travel motor with disc brake
- Swivel motor with disc brake
- All hydraulic control

Working equipment

- Auxiliary hydraulic circuit 1
- 2 LED working lights on cab with turn-off delay and 1 LED light on the boom
- Thumb bracket and relief valve
- Dozer blade with float function

Operator's space

- ROPS/OPG (TOP, Guard, Level I) canopy
- Weight-adjustable full suspension seat
- Hydraulic pilot control levers with wrist rests
- Travel levers with foot pedals
- 12V power source
- Cup Holder
- Horn
- Retractable seat belt
- Mobile Phone Holder
- USB charger (TYPE-A)
- 7" Full Color LCD screen with jog dial
- Keyless start

Engine/Fuel system

- Double element air filter
- Auto idling system
- Water separator with drain cock
- Engine Auto Stop
- Double fuel filter

Undercarriage

- 1'1.8" (350 mm) rubber track
- 1 × upper track roller
- 4 double-flange track rollers on each side
- 2-speed travel switch on dozer lever
- 2-speed travel with auto-shift

Hydraulic system

- 1-pump load sensing system
- Pressure accumulator
- Hydraulic pressure checking ports
- Automatic activation of third line hydraulic return
- Auxiliary switch (AUX1) on right control lever
- Adjustable maximum oil flow on auxiliary hydraulic circuits 1
- TPSS (Two pattern selection system)

Others

- Tool box
- Grease gun holder
- KubotaNOW Telematics

OPTIONAL EQUIPMENT

- 6 in 1 blade with float function and BOE
- Angle blade with float function and BOE
- Cab with A/C
- Canopy lights (LED)
- Beacon lights
- 1'1.8" (350 mm) steel track
- Additional auxiliary hydraulic circuit 2 (adjustable max. oil flow control)
- Travel alarm
- Rear-view mirror
- Rear-view camera
- Air suspension seat
- Front guard

Stay connected with KubotaNOW

KubotaNOW telematics gives you the right information, when and where you need it. To access KubotaNOW telematics information, download the myKubota app and stay connected to your Kubota machine. Get information like hours, fuel level, location, temperatures, error codes, and more.



WORKING RANGE

Model		KX040-5		
A	Max. digging height	ft. in. (mm)	17'6" (5335)	
B	Max. dumping height	ft. in. (mm)	12'9.5" (3900)	
C	Max. digging depth	ft. in. (mm)	11'2.3" (3410)	
D	Max. vertical digging depth	ft. in. (mm)	7'9.9" (2385)	
E	Max. digging radius, at ground level	ft. in. (mm)	17'8.6" (5400)	
F	Max. digging radius	ft. in. (mm)	18'1.9" (5535)	
G	Min. turning radius	W/o swing	ft. in. (mm)	7'0.8" (2155)
		W swing	ft. in. (mm)	5'11.1" (1805)
H	Min. tail turning radius	ft. in. (mm)	4'3.2" (1300)	

LIFTING CAPACITY

LIFT POINT HEIGHT (ft)	LIFTING CAPACITY OVER-FRONT BLADE DOWN unit=1000 lbs			LIFTING CAPACITY OVER-SIDE unit=1000 lbs			
	LIFT POINT RADIUS (ft)			LIFT POINT RADIUS (ft)			
	8	12	14	8	12	14	
GL	6	2.72	1.91	1.75	2.71	1.62	1.29
	4	3.56	2.14	1.87	2.82	1.58	1.27
	2	4.13	2.33	1.98	2.73	1.55	1.25
GL	0	4.31	2.45	2.03	2.69	1.53	1.24

Machine with cab and rubber crawler, without bucket, with standard blade

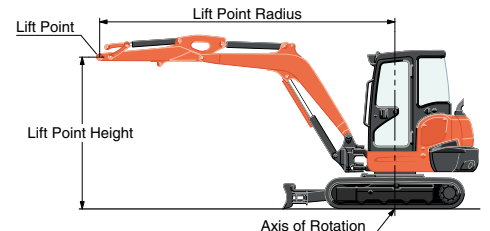
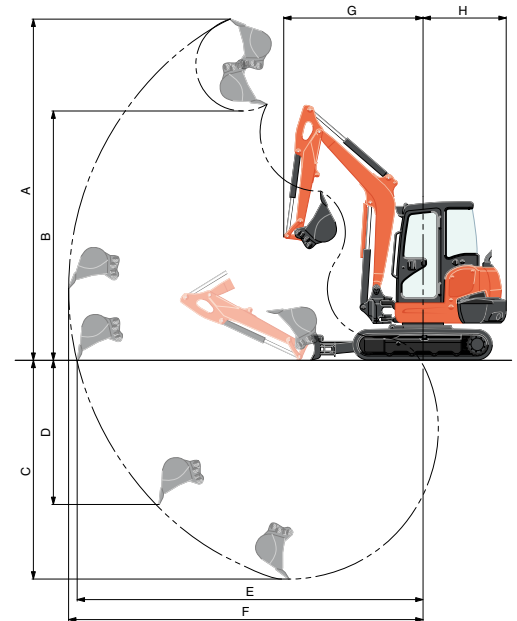

SPECIFICATIONS

Model		KX040-5	KX040-5 Angle Blade	KX040-5 6-in-1 Blade	
Type of ROPS / OPG (TOP Guard, Level I)		Canopy / Cab			
Type of tracks		Rubber, Steel	Rubber, Steel	Rubber, Steel	
Engine	Model	Kubota D1803-CR-TE5-BH5 / D1803-CR-TE5-BH6			
	Output (SAE J1995 gross)	HP (kW) / rpm	40.3 (30.1) @2200		
	Output (SAE J1349 net)	HP (kW) / rpm	39.1 (29.2) / 38.9 (29.0) @2200		
	Displacement	cu. in. (cc)	111.4 (1826)		
Dimensions	Overall length	ft. in. (mm)	16'8.2" (5085)		
	Overall height	ft. in. (mm)	8'1.6" (2480) / 8'2.0" (2490)		
	Overall width	ft. in. (mm)	5'6.9" (1,700)	5'10.9" (1800)	
	Min. ground clearance	Rubber / Steel ft. in. (mm)	1'1.0" (330) / 1'1.3" (338)		
Hydraulic system	Pump capacity	GPM (ℓ/min)	29.1 (110.0)		
	Auxiliary hydraulic flow	AUX1 / AUX2 GPM (ℓ/min)	17.2 (65.0) / 9.8 (37.0)		
	Max. breakout force	Bucket* / Arm lbf. (kgf)	9397 (4262) / 4114 (1866)		
Drive system	Travel speed	Low / High mph (km/h)	1.7 (2.7) / 3.1 (5.0)		
	Max. traction force	Low speed lbf. (kgf)	5868 (2661.5)		
	Tumbler distance	ft. in. (mm)	5'7.3" (1710)		
	Crawler length	Rubber / Steel ft. in. (mm)	7'1.6" (2175) / 7'3.2" (2215)		
	Shoe width	ft. in. (mm)	1'1.8" (350)		
	Ground contact pressure	Rubber Canopy / Cab psi (kPa)	4.5 (31.1) / 4.7 (32.1)	4.7 (32.6) / 4.9 (33.6)	4.9 (33.8) / 5.0 (34.8)
	Steel Canopy / Cab psi (kPa)	4.6 (31.5) / 4.7 (32.5)	4.8 (32.9) / 4.9 (33.9)	4.9 (34.1) / 5.1 (35.1)	
Swing system	Unit swing speed	rpm	9.2		
	Boom swing angle	degree	70 / 55		
Blade	Dimensions	Width	ft. in. (mm)	5'6.9" (1700)	5'10.9" (1800)
		Height	ft. in. (mm)	1'1.8" (350)	1'3.2" (385)
	Max. lift above ground	ft. in. (mm)	1'3.7" (400)	1'4.5" (420)	1'5.0" (433)
	Max. drop below ground	ft. in. (mm)	1'3.9" (405)	1'8.1" (510)	1'8.7" (527)
	Angle	Left / Right	degree	-	25 / 25
		Tilt	degree	-	10 / 10
Hydraulic oil (Reservoir / System)	gal (ℓ)	9.8 (37) / 17.7 (65)			
Fuel reservoir	gal (ℓ)	17.4 (66.0)			
Operating weight (Including operator's weight @ 165 lbs.)	Rubber Canopy / Cab	lbs. (kg)	9182 (4165) / 9480 (4300)	9623 (4365) / 9910 (4495)	9965 (4520) / 10251 (4650)
	Steel Canopy / Cab	lbs. (kg)	9348 (4240) / 9645 (4375)	9777 (4435) / 10075 (4570)	10119 (4590) / 10417 (4725)

*Specification data when using powerhole.

DIMENSIONS

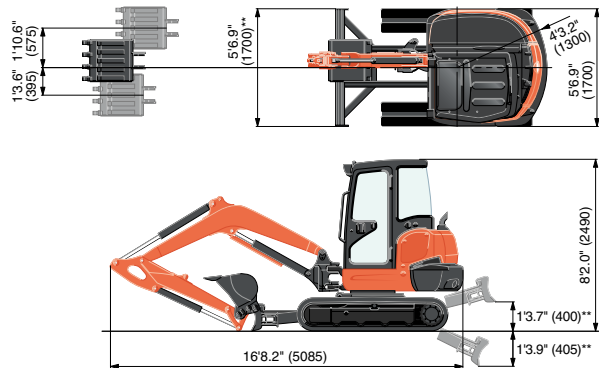

6-in-1 Blade

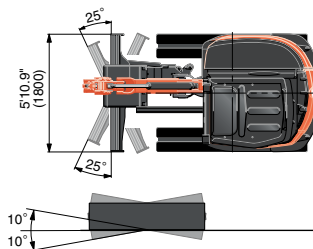

Angle Blade

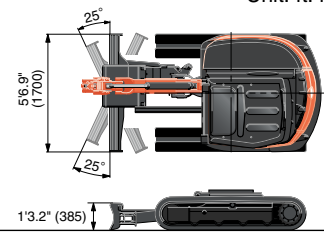

Unit: ft. in. (mm)

**Specifications for Standard blade model.

Kubota Tractor Corporation reserves the right to change the stated specifications without notice. This brochure is for descriptive purposes only and reasonable efforts were used to set forth the contained information; some items shown may be optional and some products shown may not be available at all dealerships. Kubota disclaims all representations and warranties, express or implied, or any liability from the use of this brochure. For complete warranty, safety and product information, consult your local Kubota dealer and the operator's manual. Power (HP/KW) and other specifications are based on various standards or recommended practices. For your safety, Kubota strongly recommends the use of a Followover Protective Structure (ROPS) and seat belt in almost all applications. This brochure is intended for the United States and US territories only. For information regarding Kubota products or services outside these areas, see Kubota Corporation's global web site. Kubota does not provide parts, warranty or service for any Product which is re-sold or retailed in any country other than the country for which the Product(s) were designed or manufactured.



KUBOTA TRACTOR CORPORATION

1000 Kubota Drive, Grapevine, TX 76051 Tel 888-4 KUBOTA

Visit our web site at: www.kubotausa.com

©2024 Kubota Corporation



**Kubota
Genuine Parts**
for excellent
performance,
durability and
safety

