



For Earth, For Life
Kubota

U

KUBOTA ZERO TAIL SWING COMPACT EXCAVATOR U17-5

Kubota's U17-5 zero-tail swing compact excavator gives you the performance and efficiency you need in tight spaces.



PERFORMANCE

Advanced hydraulic systems for superior performance and operability.

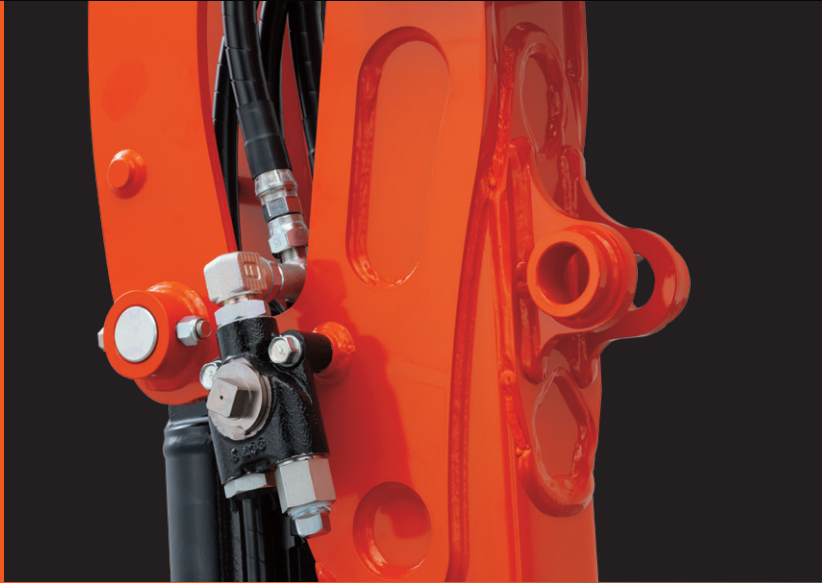

Two-pattern Selection System (TPSS)

TPSS is standard equipment, allowing the operator to select the most familiar operating control pattern, either ISO or SAE.

Thumb Bracket

The hydraulic thumb and relief valve make short work of a variety of loading and material handling jobs. The factory installed mounting brackets and hydraulics significantly reduce the time needed to mount the optional hydraulic thumb.

AUX Diverter Valve

The diverter valve allows the hydraulic thumb attachment to remain connected while diverting oil flow to other attachments when needed, reducing transition time between attachments and improving overall productivity.

Engine Auto Idle

Engine RPM is instinctively reduced when high engine speed isn't needed. Move any control lever and the engine RPM immediately returns.

Telematics Standard

The Kubota telematics solution connects your Kubota equipment to the tools you use. Get critical information like accumulated hours, fuel level, location, temperatures and more. KubotaNOW gives you the right information when and where you need it.

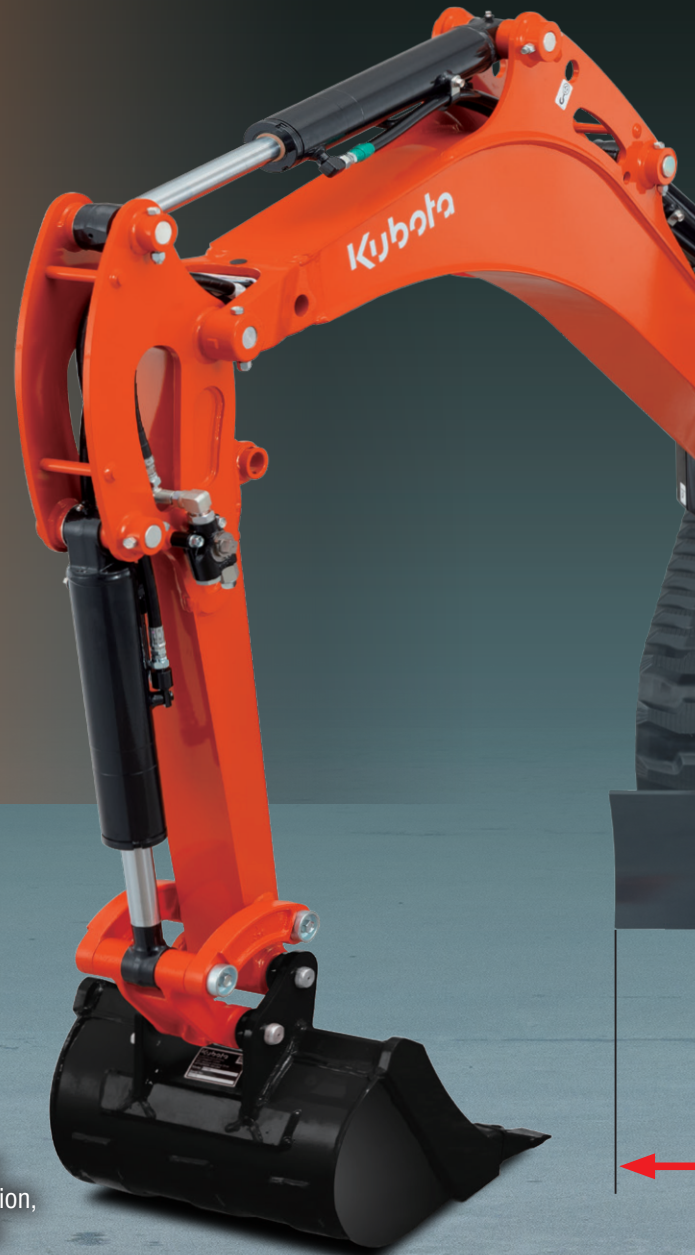

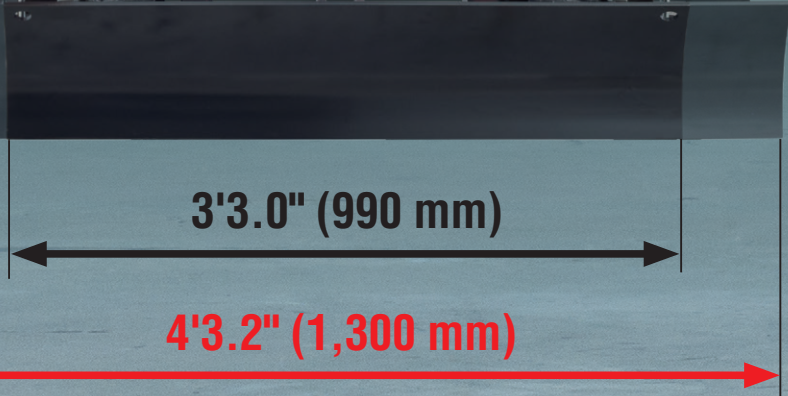

AUX Controlled By Hand

The U17-5 features AUX hand control. Proportional flow is controlled by a convenient thumb-operated switch. Applications that require a constant oil flow can be controlled from a forefinger-operated on/off switch. Up to five oil flow rates can be preset for different attachments through the meter panel, allowing quick and convenient selection for the correct oil flow setting for each type of attachment.



Zero-Tail Swing

Zero-tail swing means you'll never again worry about what is to the side or behind you while you work. No matter how far you turn, the tail always remains within the width of the tracks. Zero-tail swing also ensures excellent balance, stability and faster operation, making the U17-5 ideal for jobs in congested urban areas.

Improved Stability

We improved stability by extending the rear end by 1.2 inch (30 mm) to be able to handle heavy weight attachments which require AUX, like a breaker.

Travel Speed Switch

By placing the travel speed switch on the dozer lever, dozing operations have become faster and easier. The new location also frees up space on the floor for improved operator comfort.

Variable Track Gauge

The U17-5's track gauge can be expanded to a maximum of 4'3.2" (1,300 mm) to optimize stability when using heavy attachments. For better side stability, the maximum track expansion has been increased by 2.4" (60 mm). The track gauge can also be retracted to 3'3.0" (990 mm) for easier movement through narrow passageways and to allow work in tight spaces.



INTERIOR

All-new levels of comfort.

Comfortable Operator Space

A comfortable operator is a productive operator. That's why the U17-5 operator's space has been enhanced to ensure optimum comfort and efficiency throughout the working day. All controls are ergonomically placed for faster and easier operation. The front meter panel can be checked without shifting your eyes from the task in hand. The mobile phone holder is within easy reach from the operator's seat, and you can charge your phone while you work.

- A. Meter panel
- B. Cup holder
- C. USB charger (TYPE-A)
- D. Mobile phone holder
- E. Engine throttle dial

Wider Foot Space

The latest interior not only optimizes maneuverability, the operator has spacious legroom, increased by 1.2" (30mm) from the previous model.



Semi-Suspension Seat

Designed for better fit and comfort for long hours of work, Kubota's standard semi-suspension seat minimizes strain and operator fatigue by accommodating your individual posture and weight. A retractable seat belt is fitted as standard.



SAFETY

Safety functions to support your smooth operation.

LED Boom Work Light As Standard

Bright LED boom work light provides plenty of illumination for nighttime tasks. Also, we can fit a canopy LED light as optional equipment.



Engine Emergency Stop

In an emergency, the operator can stop the engine with the flip of a single switch.

Swivel Parking Brake

Transport is easier in all positions with the swivel parking brake.

Unload Lever

Changing the hydraulic circuit, all operations including the swing, dozer, and AUX can now be locked with the control lock lever.

ROPS/OPG (TOP Guard, Level I) Canopy

The ROPS and the OPG (TOP Guard, Level I) canopy meet the applicable ISO, SAE and OSHA standards, providing protection from accidental rollovers, falling objects, and helps ensure an extra level of safety and security on the job.

- A. Fuel level gauge
- B. Water temperature gauge
- C. Warning lamps (overheating, hydraulic, battery)
- D. LCD display (time, hour, rpm)

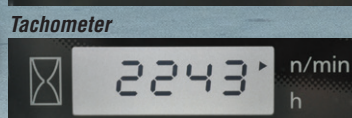
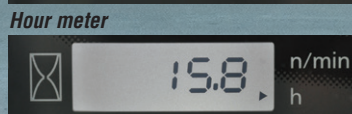

Front Meter Panel

Following the excellence of Kubota's Intelligent Control System, the front meter panel puts convenience at the operator's fingertips. The user-friendly meter panel is positioned to the front right corner of the operator for better visibility, and features one-touch button operation to view the time, hour meter and tachometer. Warning lamps with code numbers on the display will alert you in case of conditions such as overheating, hydraulic problems or low battery. With easier access, simpler settings, easy-to-read indicators and alerts, you'll be aware of the excavator's functioning status.

SERVICE

Easier accessibility to all major components simplifies inspections and repairs.



A. Radiator

B. Battery

C. Water separator

D. Air cleaner

E. Starter motor

F. Coolant tank

Easy Maintenance

When maintenance is simple, downtime is greatly reduced and you're more productive. With the U17-5, routine maintenance is easy. The rear bonnet and the left side cover opens up without the need for tools. This allows for quick access to the engine oil dipstick, water separator, radiator, battery and much more. Plus, for extra strength and easier repairs, the U17-5s bonnet and side covers are made of steel.

Boom Cylinder

The boom cylinder is situated above the boom for maximum protection, especially during breaker or dumping operation. Movement speeds of front attachments and lifting power have been well adjusted thanks to the boom cylinder's large-diameter rod and optimal hydraulic pressure.

Two-Piece Hose Design

When an on-site replacement of a dozer cylinder supply hose is necessary, its two-piece design simplifies the job.

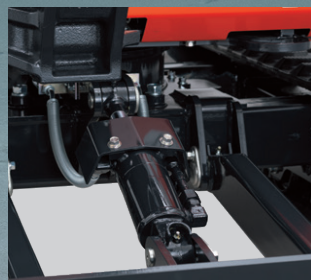

Protected Motor Hoses

Kubota has enclosed the travel motor hoses within the track frame for added protection—a unique feature for mini excavators of this class.



U17-5 OPTIONS

STANDARD EQUIPMENT

Safety system

- Engine start safety system (Unload lever)
- Swivel parking brake
- Control lock lever
- Engine emergency stop

Engine / Fuel system

- Kubota original engine
- Double-element air cleaner
- Auto idling system
- Water separator with filter

Working equipment

- 1 LED working light on the boom
- Tie down points on the top frame
- Thumb bracket and relief valve
- 950mm arm

Operator's space

- ROPS (Roll-over Protective Structure, ISO3471)
- OPG (Operator Protective Guard, Top Guard) Level1
- Weight-adjustable semi-suspension seat

- Mobile holder
- 12V power source
- USB charger (TYPE-A)
- Hydraulic pilot control levers with wrist rests
- Dial accel
- Front meter panel

Undercarriage

- 9" (230mm) wide rubber track
- Variable track system
- Double flange track rollers
- 3 outer flange-type track rollers on each track
- 2-speed travel switch on dozer lever

Hydraulic system

- Hydraulic pressure checking ports
- Independent travel circuit
- Auxiliary activation with thumb button
- Adjustable maximum oil flow on auxiliary circuit
- TPSS (Two pattern selection system)
- Variable displacement pump
- Auxiliary circuit proportional flow control at hand
- Pressure accumulator

Others

- KubotaNOW Telematics
- Tool box

OPTIONAL EQUIPMENT

- LED working light on canopy
- Travel alarm

Stay connected with **KubotaNOW**

KubotaNOW telematics gives you the right information, when and where you need it. To access KubotaNOW telematics information, download the myKubota app and stay connected to your Kubota machine. Get information like hours, fuel level, location, temperatures, error codes, and more.



LIFTING CAPACITY

LIFT POINT HEIGHT (ft)	LIFTING CAPACITY OVER-FRONT BLADE DOWN unit=1000 lbs				LIFTING CAPACITY OVER-SIDE (track width 51.2 in.) unit=1000 lbs			
	LIFT POINT RADIUS (ft)				LIFT POINT RADIUS (ft)			
	6	8	10		6	8	10	
GL	6	0.54	0.61	—	0.54	0.61	—	
	4	1.01	0.73	0.60	0.94	0.61	0.44	
	2	1.28	0.82	0.61	0.87	0.58	0.42	
	0	1.19	0.80	0.57	0.85	0.56	0.42	

Machine with ROPS canopy and rubber crawler, without bucket

WORKING RANGE

Model	U17-5			
A	Max. digging height	ft. in. (mm)	11'6.2" (3510)	
B	Max. dumping height	ft. in. (mm)	8'1.2" (2470)	
C	Max. digging depth	ft. in. (mm)	7'6.2" (2290)	
D	Max. vertical digging depth	ft. in. (mm)	4'10.7" (1490)	
E	Max. digging radius, at ground level	ft. in. (mm)	12'6.4" (3820)	
F	Max. digging radius	ft. in. (mm)	12'8.8" (3880)	
G	Min. turning radius	w/o swing	ft. in. (mm)	4'8.7" (1440)
		with swing	ft. in. (mm)	3'11.6" (1210)
H	Min. tail turning radius	ft. in. (mm)	2'1.6" (650)	

Please note:

* The lifting capacities are based on ISO 10567 and do not exceed 75% of the static tilt load of the machine or 87% of the hydraulic lifting capacity of the machine.

* The excavator bucket, hook, sling and other lifting accessories are not included on this table.

* Specifications are subject to change without notice for purpose of improvement.

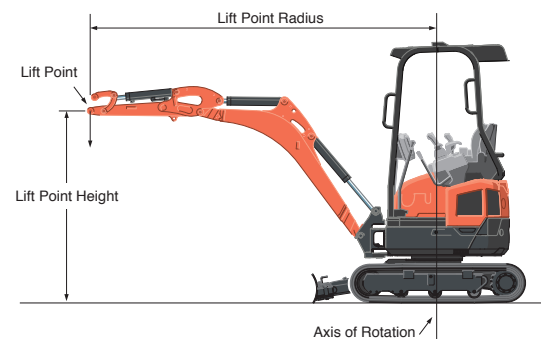
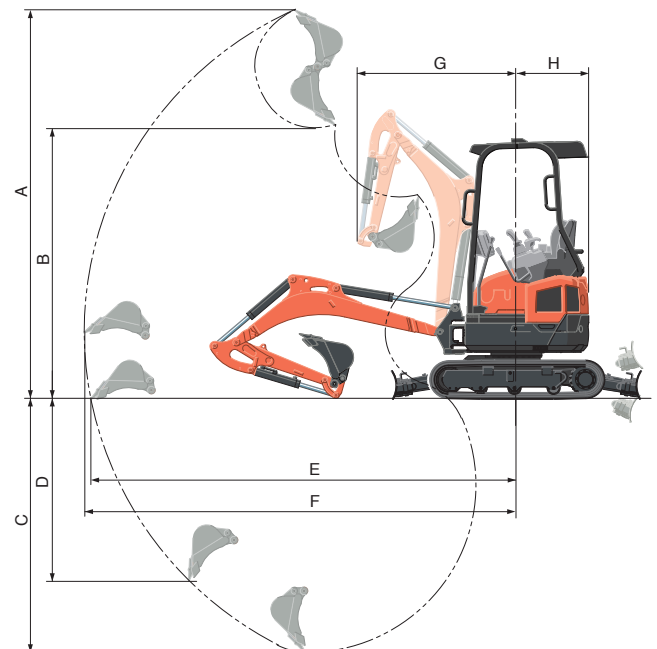

SPECIFICATIONS

Model		U17-5		
Type of ROPS / OPG (TOP Guard, Level I)		Canopy		
Type of tracks		Rubber		
Engine	Model	D902-E4-BH-6EU		
	Output (SAE J1995 gross)	HP (kW) / rpm	16.1 (12.0) / 2300	
	Output (SAE J1349 net)	HP (kW) / rpm	15.1 (11.3) / 2300	
	Displacement	cu. in. (cc)	54.8 (898)	
Dimensions	Overall length	ft. in. (mm)	11'7.7" (3550)	
	Overall height	ft. in. (mm)	7'9.3" (2370)	
	Overall width	Standard	ft. in. (mm)	4'3.2" (1300)
		Narrow	ft. in. (mm)	3'3.4" (1000)
	Track gauge	Standard	ft. in. (mm)	4'3.2" (1300)
		Narrow	ft. in. (mm)	3'3.0" (990)
Min. ground clearance	in. (mm)	6.1" (155)		
Hydraulic system	Pump capacity	GPM (ℓ/min)	4.6 (17.3)	
	Auxiliary hydraulic flow	GPM (ℓ/min)	7.3 (27.7)	
	Max. breakout force	Bucket / Arm	lbf. (kgf)	15.8 kN (1609) / 8.7 kN (887)
Drive system	Travel speed	Low / High	mph (km/h)	1.4 (2.3) / 2.7 (4.4)
	Max. traction force	Low speed	lbf. (kgf)	3170 (1438)
	Tumbler distance	ft. in. (mm)	4'0.4" (1230)	
	Crawler length	ft. in. (mm)	5'2.2" (1580)	
	Shoe width	in. (mm)	9" (230)	
	Ground contact pressure	psi (kgf / cm ²)	4.0 (0.29)	
Swing system	Unit swing speed	rpm	9.4	
	Boom swing angle	Left / Right	degree	63 / 58
Blade	Dimensions	Width Standard / Narrow	ft. in. (mm)	4'3.2" (1300) / 3'3.0" (990)
		Height	in. (mm)	10.2" (260)
	Max. lift above ground	in. (mm)	11.0" (280)	
	Max. drop below ground	in. (mm)	8.1" (205)	
Hydraulic oil (Reservoir / System)		gal (ℓ)	3.4 (13) / 5.8 (21.8)	
Fuel reservoir		gal (ℓ)	5.3 (20)	
Operating weight (Including operator's weight @ 165 lbs.)		lbs. (kg)	3902 (1770)	

DIMENSIONS

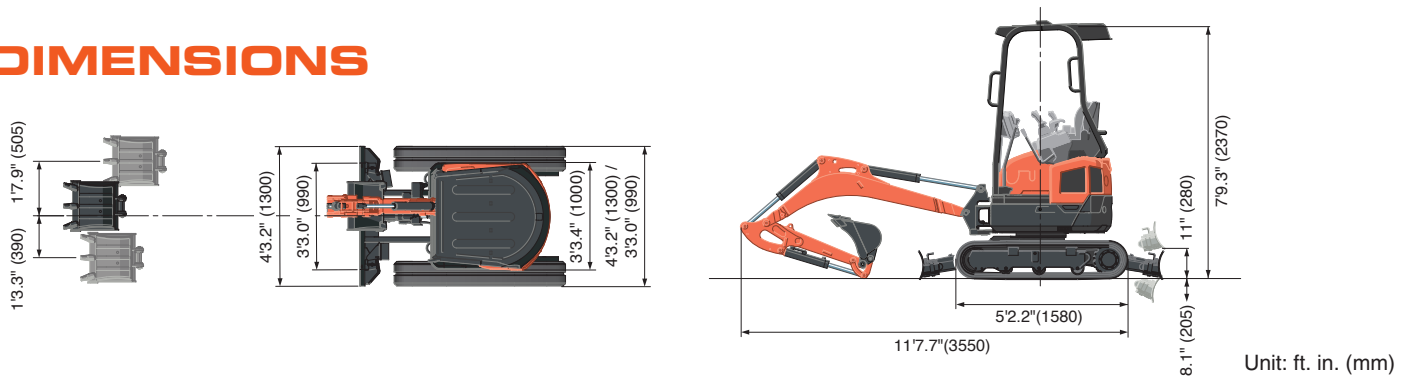

Kubota Tractor Corporation reserves the right to change the stated specifications without notice. This brochure is for descriptive purposes only and reasonable efforts were used to set forth the contained information; some items shown may be optional and some products shown may not be available at all dealerships. Kubota disclaims all representations and warranties, express or implied, or any liability from the use of this brochure. For complete warranty, safety and product information, consult your local Kubota dealer and the operator's manual. Power (HP/KW) and other specifications are based on various standards or recommended practices. For your safety, Kubota strongly recommends the use of a Rollover Protective Structure (ROPS) and seat belt in almost all applications. This brochure is intended for the United States and US territories only. For information regarding Kubota products or services outside these areas, see Kubota Corporation's global web site. Kubota does not provide parts, warranty or service for any Product which is re-sold or retailed in any country other than the country for which the Product(s) were designed or manufactured.



KUBOTA TRACTOR CORPORATION

1000 Kubota Drive, Grapevine, TX 76051 Tel 888-4 KUBOTA

Visit our web site at: www.kubotausa.com

©2025 Kubota Corporation

